

FI Series

User Manual

Including ICON[™] information



INTRODUCTION

Copyright

This manual remains the copyrighted property of FasTest, Inc. It is solely supplied to our customers and operators of our products and forms part of the product. This documentation may not be duplicated or made accessible to third parties, in particular competitive companies, without our prior written permission.

Scope

This manual supports FasTest, Inc. components only. If special components, including but not limited to serial hubs, power supplies, PLC's are included based on a customer's specification or special request, it is the customer's responsibility to consult support materials and technical support specific to these special components provided by the third party manufacturers. FasTest, Inc. assumes no liability for misuse, misapplication, or support for components that are not the FasTest, Inc. brand.

Using the products in a manner not specified in this manual can impair the safety of operators and equipment.

We reserve the right to make alterations for the purpose of technical improvement.

Technical Support is available from: fastsales@fastestinc.com

Edition: WP008 Rev G; 3/17/2020 En

Table of Contents

Overview	1
Specifications	2
Installation and Operating Instructions	3
Maintenance and Care	6
ICON™ Calibration	9, 10, & 11
Seal Life™ Calibration	12
ICON™ Wiring Diagrams	13
Troubleshooting	14
Warranty	14

OVERVIEW

The FI Series delivers fast, leak free connections for vacuum and pressure testing, fluid filling or flushing applications. The connector seals internally to smooth tubes or threaded ports of many materials. Compressed air activates the seals for a leak tight, non-marring connection for air and liquid applications - even with rough and oily surfaces.

Optional Features:

ICON - Intelligent Connection:



SURE SEAL™

Instant feedback verifies a good connection has been made and recognizes a failure prior to starting a test. Isolate your product, improve first pass yield, and collect data on connection status.



SEAL LIFE™

Automatically alert operators the main seal has worn and must be replaced. Prevent wasteful false failures while optimizing maintenance programs.

Extended Shaft:

Connectors with extended shafts are designed for sealing remote ports or for applications requiring connectors to be offset rather than side-by-side mounting. This may be required when multiple test ports have close center-to-center distances. See Figure 1 for an example.

Stroke Limiter:

All FI connectors are equipped with a stroke limiter. This feature will prevent over pressurization and excessive travel of the FI seals when pilot pressure is applied to an FI not placed in a test piece. Additionally, if an FI stroke limiter prevents sufficient pressurization for a sealing or testing application, it may be removed very easily without reducing the effectiveness of the connector.



Figure 1. FI connector with extended shaft

Contents:

A new FI comes with only the connector (A), seal sets (B) are sold separately. **Users must install the seal set before use.**



Figure 2A. FI connector and seal set

ICON™

A new FI with ICON™ comes with only the base connector (A), **seal sets (B), and cable sets (C) are sold separately. Users must install the seal set before use.**

(C) Cable Set with M8 Termination, 6' (Not Included)



Figure 2B. ICON™ cable

SPECIFICATIONS

Operating Pressure	Vacuum to 120 psi (8 bar)
Connection Profile	Internal Tubes, Bores and Threads
Termination Profile	Female 10-32" UNF, M5X8, NPT/BSPP: 1/8" to 2 1/2"
Mounting Port	Female 10-32" to 3/8-24" UNF, M5X8 to M11X1.5, 4-40" to 3/8-24" UNC
Pilot Port	Female 10-32" UNF, M5X8, 1/8" NPT/BSPP
Pilot Pressure	60-120 psi
Housing Material	Aluminum, Stainless Steel, and Potting Material
Seal Material	Standard: Neoprene, Urethane Optional: FKM (Viton), Buna-N or EPDM
Operating Temperatures	0°F to 250°F (-17°C to 37°C) Neoprene 32°F to 180°F (0°C to 37°C) Urethane 0°F to 100°F (-17°C to 37°C) Intelligent Connection Technology

ICON™

SSR (max 100 mA load)
Analog (0-10V)

Supply voltage: 24V

Sealed electronics

Internal memory stores
calibration points

CHART 1: Dimensions

FI Body Sizes	A	B	C	D	E	F	G	L	H CV04 Only	J CV04 Only	K CV04 Only	M CV04 Only
FI01 FIM01	1.98 (50.3)	1.25 (31.8)	10-32 UNF M5x0.8	10-32 UNF M5x0.8	0.80 (20.4)	0.40 (10.2)	10-32 UNF M5x0.8	0.48 (12.2)	0.42 (10.7)			0.16 (4.1)
FI1, FI2 FIM1, FIM2	2.44 (62.0)	1.57 (39.9)	1/8" NPTF 1/8 BSPP	1/8" NPTF 1/8 BSPP	1.02 (26.0)	0.51 (13.0)	1/4-28 UNF M6x1.0	0.57 (15.8)	0.51 (13.0)	0.55 (14.0)	.41 (10.4)	0.25 (6.4)
FI3, FI4 FIM3, FIM4	2.61 (66.3)	2.36 (60.0)	1/8" NPTF 1/8 BSPP		1.60 (40.7)	0.80 (20.4)		0.71 (28.0)	0.71 (18.0)			0.45 (11.4)
FI5, FI6 FIM5, FIM6	3.68 (93.5)	3.49 (88.7)	1/2" NPTF 1/2 BSPP		2.31 (58.7)	1.16 (29.5)		1.24 (41.2)	1.1 (27.9)			0.85 (21.6)
FI7, FI8 FIM7, FIM8	3.36 (93.5)	4.20 (106.7)	3/4" NPTF 3/4 BSPP		3.00 (76.2)	1.50 (38.1)		1.33 (42.4)	1.47 (37.3)			1.22 (31.0)

FI

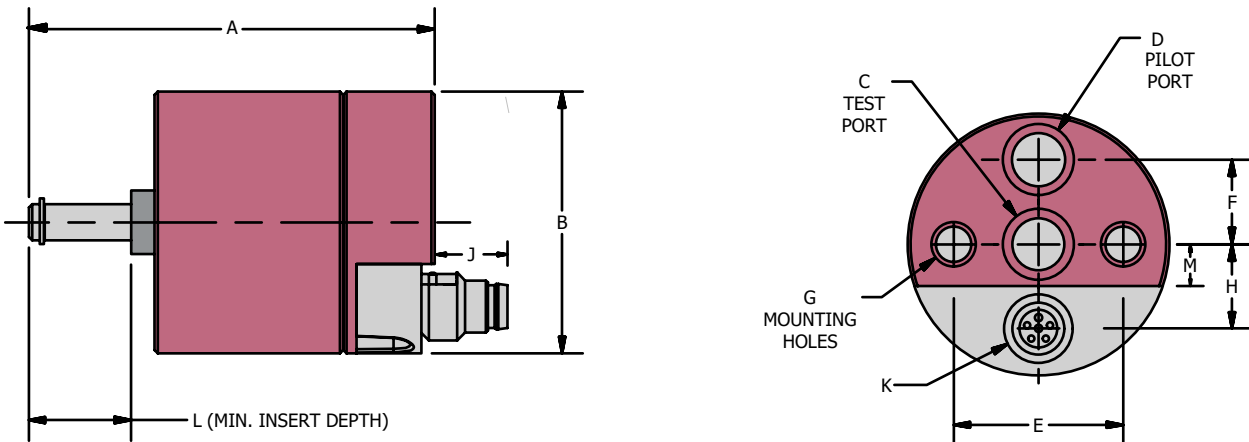
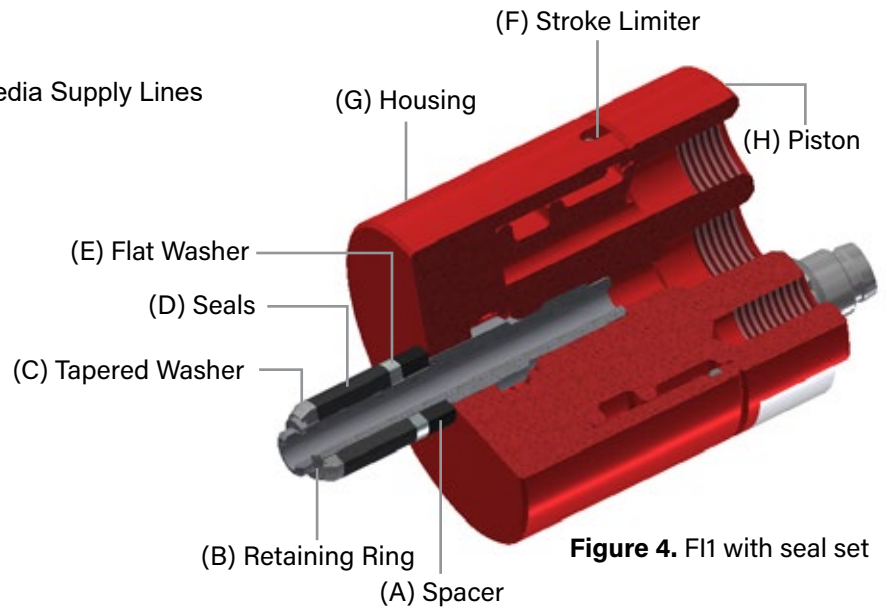

Figure 3. Connector Dimensional Features

INSTALLATION AND OPERATING INSTRUCTIONS

Standard and ICON™ versions: read and understand each of the following procedures before operating the connector.

1. Installation of New Seals
2. Mounting the Connector
3. Attachment of Pilot Pressure and Test Media Supply Lines
4. Connector Operation Instructions
5. ICON Wiring Diagram



1. Installation of New Seals

- 1.1. For new seal installation/replacement, remove retaining ring (B) from shaft tip and slide off old seal (D) and washers (C & E). Spacer (A) is to remain on connector shaft.
- 1.2. A seal set (FIS-XXX) contains elastomer seals, two washers and a retaining ring. Verify that seals and washers are the same sizes (outside diameter).
- 1.3. Assemble seal set onto the shaft per Figure 4.
- 1.4. Attach new retaining ring (B) to groove in shaft tip. **The flat side of the retaining ring must face away from the washer.**
- 1.5. A tapered washer (C) with a counterbore is used at the shaft end on all FI01, FI1, FI2, FI3, and FI4 connectors. The retaining ring will be contained within the counterbore when pilot pressure is delivered to the connector.

2. Mounting the Connector

The connector must be secured to the test piece with a mechanical or another device to assure the connector is not uncoupled from the test piece by the uncoupling force of the test itself. The securing or holding device may be a fixture, clamp, cylinder, or other appropriate means that prevents ejection of the test piece from the connector.

Uncoupling force example:

Test piece has a ½" O.D. and is tested at 100 psi maximum. Uncoupling force = area (πr^2) x pressure = $\pi(.25)^2 \times 100 \approx 20$ lbs. The secured device should be designed to withstand this force and include an adequate margin for safety. Do not activate the connector without an adequate and safe securing mechanism.

Mount the FasTest FI connector to the fixture or appropriate device using either threaded mounting holes on the rear of the connector body or appropriate adapter.

3. Attachment of Pilot Pressure and Test Media Supply Lines

- 3.1. Attach pilot pressure line to pilot port "D", Figure 5. Note: A pneumatic regulated source is required to maximize seal life and assure optimum seal-ability for the application. The pilot pressure should be minimized to maintain sealing on the test piece without excessive compression of the seal. Excess pilot pressure may reduce the life of the seal
- 3.2. Attach test media line to test port "C", Figure 5.
- 3.3. Provide a means whereby test pressure will not be introduced until pilot pressure required to seal is reached. The means should also provide quick exhaust of test pressure in the event pilot pressure falls below the minimum required to seal.

Note: Test and pilot pressure should not be regulated by the same regulator. Failure to comply may result in harm.

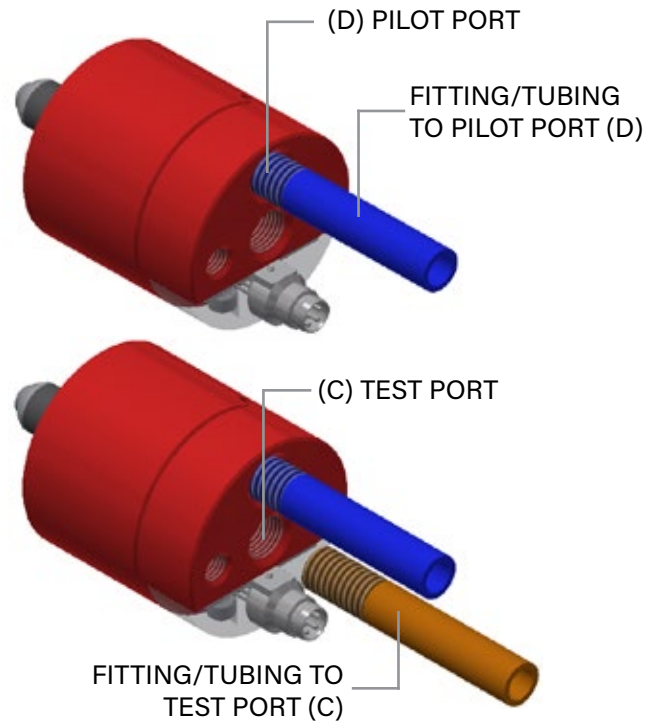
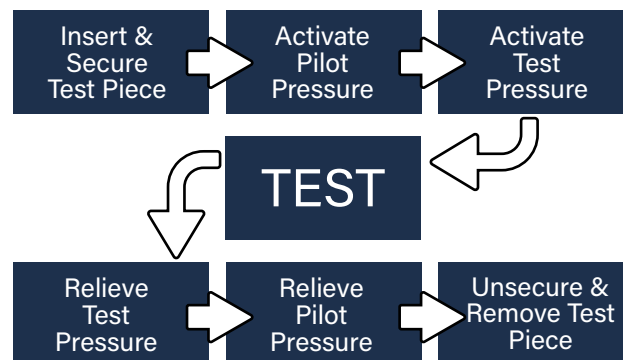

Figure 5. Attachment of Lines

4. Connection Operation

FasTest recommends that both the FI connector and the test piece are secured by mechanical devices before proceeding with the following sequence:

Activate the connector testing sequence as shown below.



- 4.1. Place the test piece over the end of the connector and secure it. Make sure the test piece is inserted into the required minimum insertion length. This will assure proper location relative to the seals. Make sure the connector and test piece are secure.
- 4.2. Apply pilot pressure to seal against the part. Generally, a 60 to 90 psi pneumatic pilot pressure source is required. CAUTION: Do not activate PILOT or TEST PRESSURE without test piece in place.
- 4.3. With pilot activated, introduce gas or liquid through the FasTest FI connector.
- 4.4. Perform testing operation.
- 4.5. Relieve test pressure.
- 4.6. Relieve pilot pressure.
- 4.7. Remove test piece.

5. ICON™ WIRING

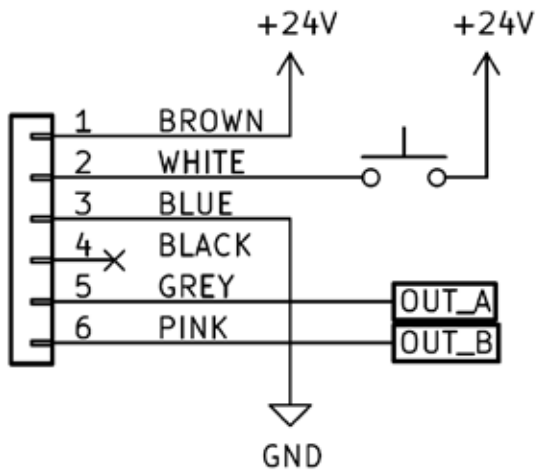
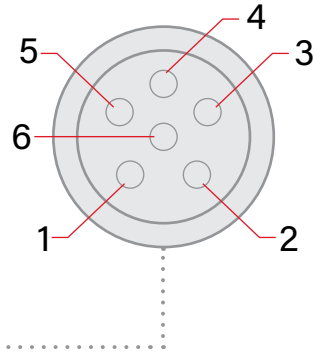
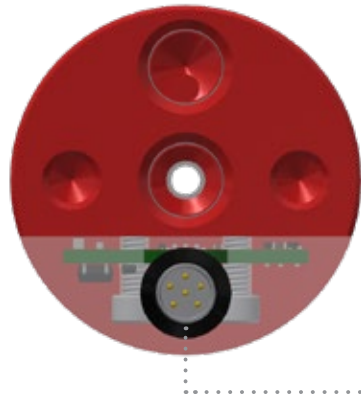

Figure 6A. Solid State Relay Application Electrical Diagram

Pinout/Standard M8 Cables		
Pin Number	Wire Color	Description
1	BROWN	24 VDC
2	WHITE	CALIBRATION
3	BLUE	GROUND
4	BLACK	NC
5	GREY	SSR CONTROL A
6	PINK	SSR CONTROL B

Figure 6B. CV04 SSR Pinout

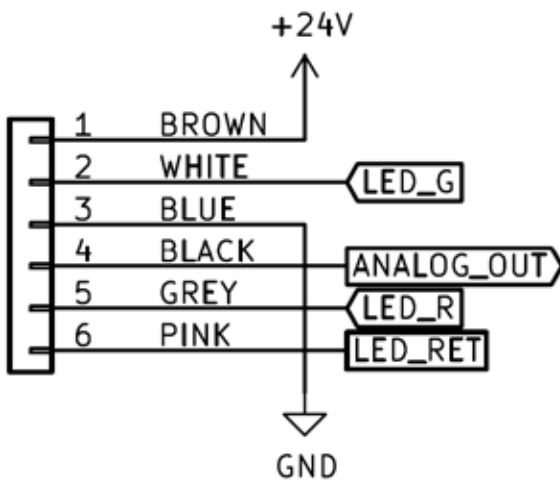

Figure 7A. Analog Application Electrical Diagram

Pinout/Standard M8 Cables		
Pin Number	Wire Color	Description
1	BROWN	24 VDC
2	WHITE	LED GREEN
3	BLUE	GROUND
4	BLACK	ANALOG OUTPUT
5	GREY	LED RED
6	PINK	LED RETURN

Figure 7B. CV04 Analog Pinout

MAINTENANCE AND CARE

A daily, weekly, and periodic inspection of the connector by a competent person is recommended. Lubricate connector at regular intervals. Petroleum jelly is recommended but care should be taken to verify the lubricant is compatible with the application. Users must establish a regular interval for maintenance as determined by the user media and operational environment. Inspection should include damage to the body, missing or loose components, leak tightness, ease of operation, sufficient lubrication, wear, dirt accumulation, and damage. Use only original FasTest spare parts that are designed for the application and are subject to strict quality control. See warranty.

6. Replacing Main Seal
7. Replacing Internal Seals
8. Replacing Internal Seals on a FI with *ICON™*

6. Replacing Main Seal

- 6.1. If replacing seals only, inspect washers for warping, corrosion, or excessive wear.
- 6.2. Replace complete FasTest main seal set if washers are warped, corroded, or worn.
- 6.3. Always replace the retaining ring when changing the main seal.
- 6.4. See "Installation of New Seals" for detailed instructions.

7. Replacing Internal Seals on a Standard Connector

- 7.1. Remove retaining ring, main seal set, and spacer.
- 7.2. Slide the housing forward until the stroke limiter (F) is engaged.
- 7.3. Use a small pick to remove the snap/retaining ring. See Figure 8.
Note: if repairing a connector with ICON™, refer to step 8 below.
- 7.4. Fully remove the housing (G) from the piston (H). See Figure 8.
- 7.5. Use a small pick to remove the internal (L) o-rings. See Figure 9.
- 7.6. Lubricate the new o-rings with petroleum jelly and re-install.
- 7.7. Re-install housing, stroke limiter, spacer, main seal set, and retaining ring.

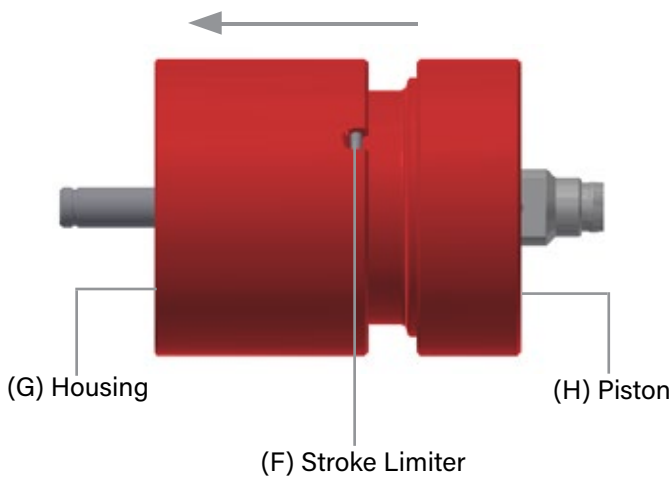

Figure 9. Removal of Stroke Limiter

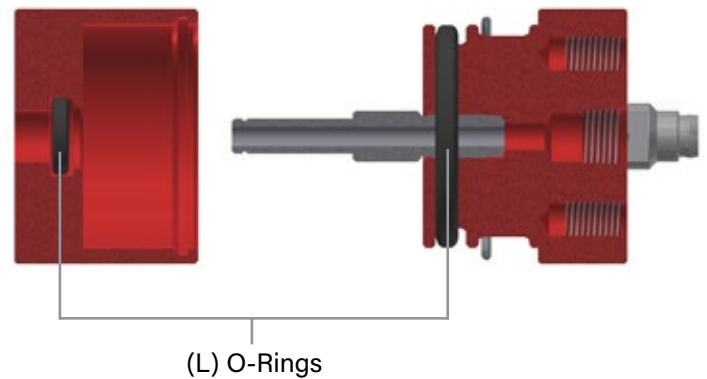

Figure 10. Removal of Internal O-Rings

ICON™

8. Replacing Internal Seals on a Connector with ICON™

- 8.1. Follow steps 7.1 through 7.3.
- 8.2. Take care when removing the housing (G) because the actuator assembly and spring can come out. See Figure 10.
- 8.3. Replace the actuator assembly and spring as shown.
- 8.4. Follow steps 7.5 through 7.7.

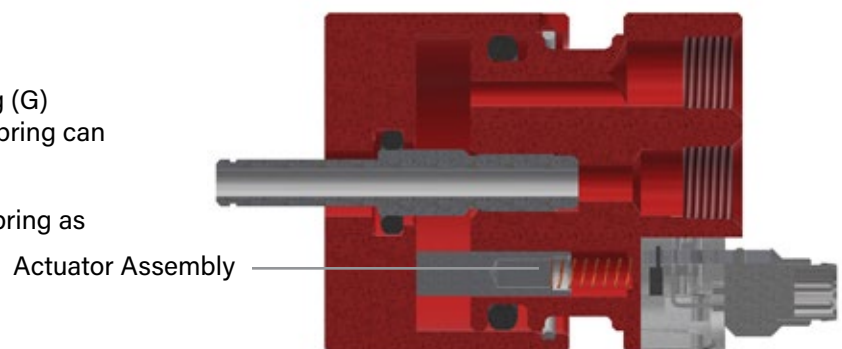

Figure 11. Actuator Assembly

CHART 2: Connector Sealing Range

FI Body Sizes	FIS Seal Set	Sealing Range	No. of Seals	Flow Ø (in)
FI01	FIS0101 FIS01-1/8NPT	.330 - .394 1/8 NPT	1 1	.06
FI1	FIS111 FIS112 FIS113 FIS1-1/4NPT	.394 - .472 .472 - .551 .551 - .630 1/4 NPT	1 1 1 1	.13
FI2	FIS221 FIS222 FIS223 FIS2-3/8NPT FIS2-1/2NPT	.630 - .709 .709 - .787 .787 - .866 3/8 NPT 1/2 NPT	1 1 1 1 1	.17
FI3	FIS331 FIS332 FIS333 FIS3-3/4NPT	.866 - .945 .945 - 1.024 1.024 - 1.102 3/4 NPT	2 2 2 1	.21
FI4	FIS441 FIS442 FIS443 FIS4-1NPT	1.102 - 1.181 1.181 - 1.260 1.260 - 1.339 1 NPT	2 2 2 1	.28
FI5	FIS551 FIS552 FIS553 FIS5-1 1/4NPT	1.339-1.457 1.457-1.575 1.575-1.693 1 1/4 NPT	3 3 3 2	.56
FI6	FIS661 FIS662 FIS663 FIS6-1 1/2NPT	1.693-1.850 1.850-2.008 2.008-2.165 1 1/2 NPT	3 3 3 2	.72
FI7	FIS771 FIS772 FIS773 FIS7-2NPT FIS7-2 1/2NPT	2.165-2.305 2.305-2.445 2.445-2.585 2 NPT 2 1/2 NPT	3 3 3 2 2	.92
FI8	FIS881 FIS882 FIS883	2.585-2.725 2.725-2.865 2.865-3.005	3 3 3	.92

● Note: Standard main seal material is Neoprene. NPT seals are Urethane. Use of less than the listed number of seals (for less insertion depth) requires a spacer. See FasTest catalog. Seal Installation Instructions included with seal sets.

ICON™ OVERVIEW

The **FI Connector** comes in two versions: solid-state relay output (CV04SSR) and analog output (CV04ANA). Both allow monitoring of the actuator position to ensure a good seal and provide visual feedback to the operator.

Each time the connector is actuated; a piston slides forward and settles at a final position. To get consistent piston travel; pilot pressure, Device Under Test (DUT), connector placement, and main seal must be consistent. If one of those attributes changes, piston travel will change and the system can be set up to alert operators.

Solid State Relay (SSR) Output

The Sure Seal feature of **ICON** connectors compares the actuator piston with user-set limits to ensure a good seal. The user can set upper and lower travel limits so that low pilot pressure, out-of-tolerance DUTs, seal wear, short connect, or other deviations from the nominal test setup can all be recognized. Alternatively, the user can set a single minimum-travel criterion, to check only that the piston has actuated as expected.

Additionally, a **Seal Life™** point can be set which overrides normal operation. When the piston actuates past the Seal Life™ point, the indicator light will turn red and the output will be disabled, signaling the user to replace the main seal.

The FI Connector retains stored limit(s) even when power is removed. Due to the fine sensor resolution and variation in seal height, calibration is recommended each time seals are replaced or the connector is re-built.

The **FI SSR** also features an indicator function which can be used to call attention to a connector that needs action. For example, it can be used to tell the technician which connector to use, or it can be used to indicate a test has already failed and a new part can be tested.

Color Indicators:

Blue Flash: the connector is on, but either not actuated or under-actuated

Solid Green: secure connection

Solid Yellow: over travel

Solid Red: Seal Life™

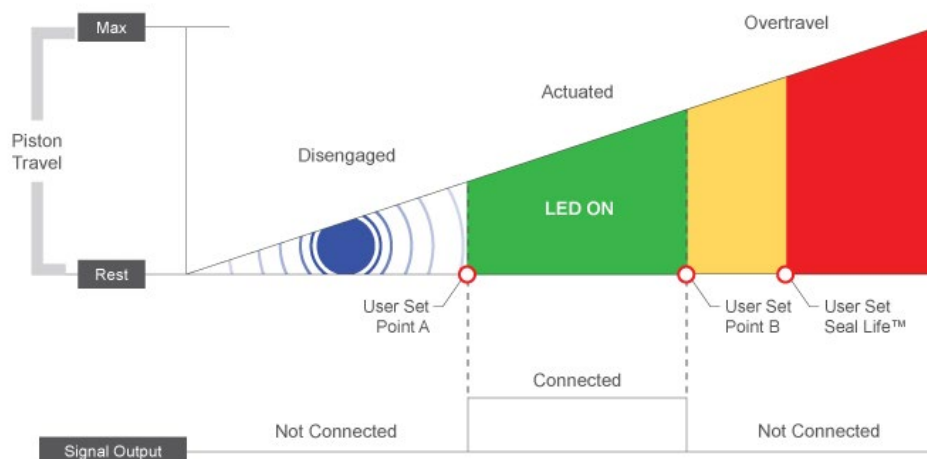

Figure 12.
ICON's Sure Seal and Seal Life color representation

Analog Output

The analog version of the FI+ allows the user to directly monitor the FI actuator position as an analog 0-10V signal. It also provides user-controlled red-and green LEDs, allowing user-defined R/Y/G indication to the operator. The CV04ANA is ideal for users that wish to use a high-capability PLC to implement advanced functionality.

ICON™ CALIBRATION - DISCRETE (SSR)

The connector has two calibration procedures, single point and dual point, that provide flexibility for different applications

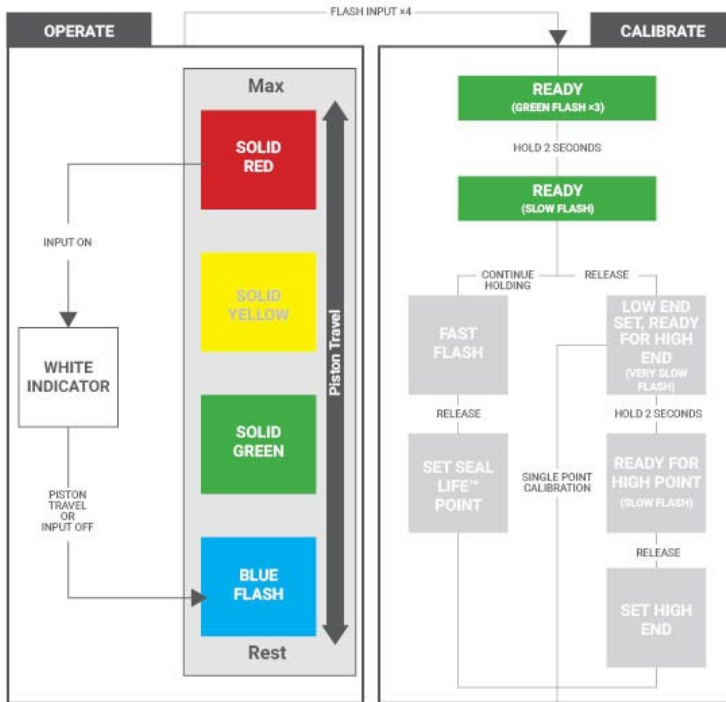

Figure 13. Calibration Flowchart

9.1. Calibration Process 1 - "Single Point Calibration"

Single Point calibration is optimized for quick calibration and users that only need to know the connector actuated to a certain point, e.g. benchtop leak testing. **Note: during calibration, the SSR output will mirror the LED indicator.**

9.1.1. Place calibration reference onto the FI and apply pilot pressure.

9.1.2. Flash input 4 times quickly to enter programming mode. A quick triple green flash at regular intervals indicates the device is in calibration mode. **Note: Programming will time-out after about 30 seconds of inactivity. A short pulse on the input will restart this timer without setting a calibration point.**

9.1.3. Apply 24V until the connector begins to flash, about 2 seconds. The lower limit, Set Point A, will be set once the button is released.

9.1.4. Wait 30 seconds for calibration mode to time-out – Output signal will remain in a closed state.

9.1.5. Remove pilot pressure and calibration reference – Output signal will switch to open state.

9.1.6. Confirm proper operation.

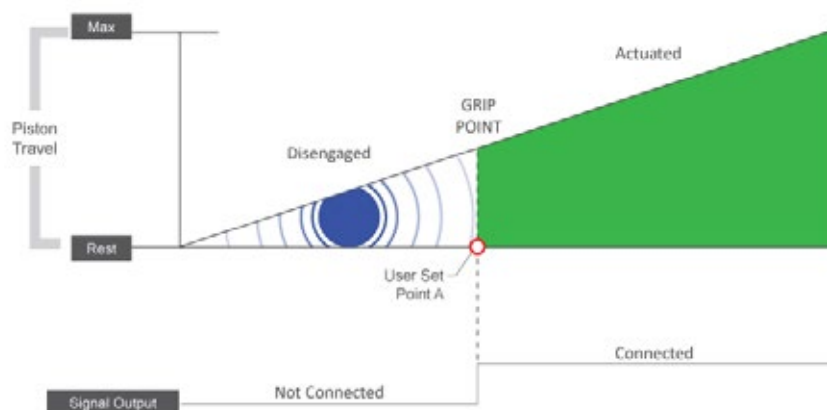

Figure 14. Single Point Calibration Graph

ICON™ - DISCRETE (SSR)

9.2 Calibration Process 2 - “Dual Point Calibration”

Process 2 is for applications that require greater control and recognition of overtravel conditions. e.g. automated leak testing and pick-n-place applications. **Note: during calibration, the SSR output will mirror the LED indicator.**

9.2.1. Place a calibration reference, representing an undersized part (undertravel condition), onto FI and apply pilot pressure.

9.2.2. Flash 24V signal on the input line 4 times quickly to enter programming mode. A quick triple green flash at regular intervals indicates the device is in calibration mode. **Note: If at any time the input is left low for more than 30 seconds, calibration mode will time-out. A short pulse on the input will restart this timer without setting a calibration point.**

9.2.3. Apply 24V to the input line until the connector begins to flash, about 2 seconds. The lower limit, set point A, will be set once the button is released. **Note: if the signal is held high for more than several seconds, the LED will begin strobing and the Seal Life™ point will be set instead.** Once the input is released, the LED will begin flashing slowly.

9.2.4. Remove pilot pressure and Calibration Reference.

9.2.5. Place a calibration reference, representing an oversized part (overtravel condition), onto the FI and apply pilot pressure.

9.2.6. Apply 24V to pin #2 for 2 seconds to set point B (Refer to Figure 15). The upper limit will be set once the button is released.

9.2.7. Remove pilot pressure and Calibration Reference.

9.2.8. Confirm proper operation.

9.2.9. As the seal wears, piston travel will increase even for a test piece of the same size. The calibration procedure can be repeated as often as necessary to account for this. To set a hard limit for piston travel, see “Seal Life™” section.

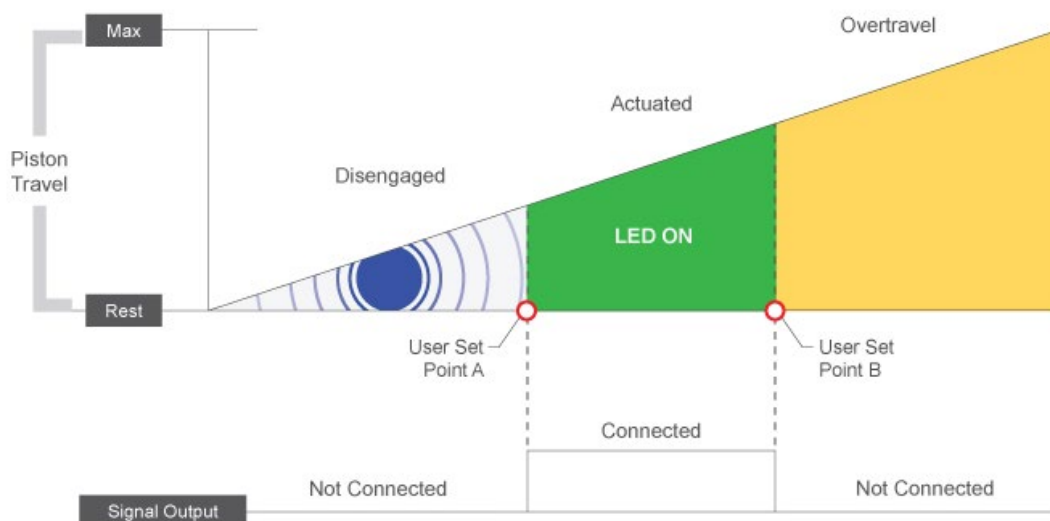

Figure 15. Dual Point Calibration Graph

SEAL LIFE™ CALIBRATION - DISCRETE (SSR)

10. Seal Life™ Calibration

Seal Life™ allows a secondary overtravel limit to be set. As the seal wears, the piston travel will increase even for a test piece of the same size. The Sure Seal™ calibration can be repeated as the seal wears to account for this. The Seal Life™ allows the user to set an upper limit on piston travel that cannot be overridden by Sure Seal™ recalibration, to indicate that the seal has reached the end of its useful life and must be replaced.

10.1. Use a calibration reference to actuate the piston to the desired Seal Life™ point. The calibration reference may be a severely oversized test reference, a machined stroke limiter, or other mechanisms.

10.2. Flash the input high 4 times in quick succession to enter programming mode. A quick triple green flash at regular intervals indicates the device is in calibration mode.

10.3. Hold the input line high. The indicator LED will start solid green. After about 2 seconds, the indicator will begin flashing green **but do not release the input**. Eventually, the indicator will begin strobing green rapidly.

10.4. At this point, the Seal Life™ point will be set when the input is released. The device will then return to normal operation.

10.5. To disable Seal Life™, perform steps 10.1 to 10.3 of the Seal Life™ calibration procedure. Then, **without releasing the input**, remove the power supply to the device.

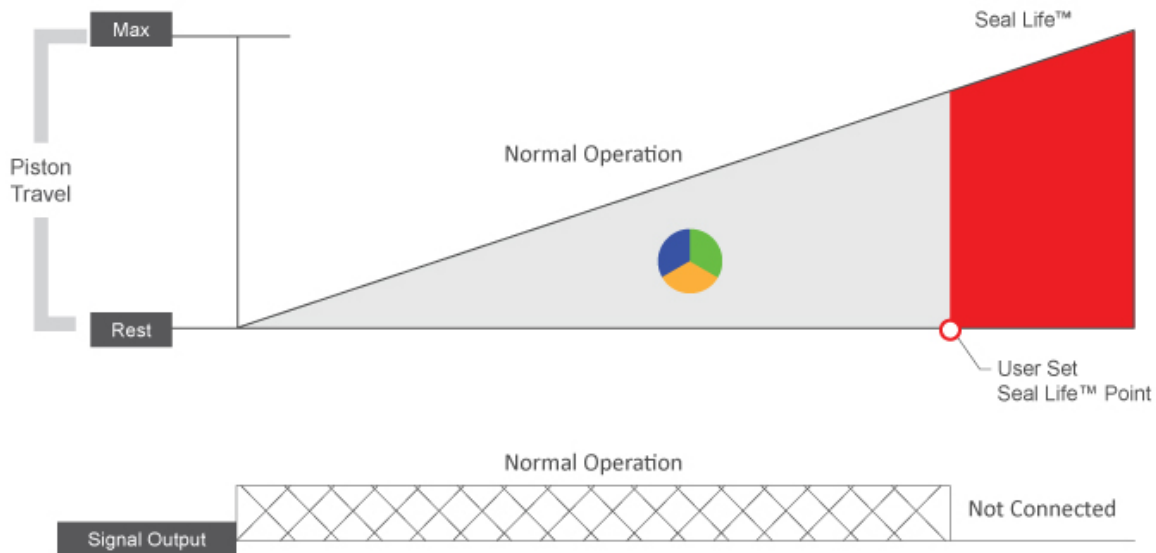

Figure 16. Seal Life™ Calibration Graph

ICON™ WIRING DIAGRAM					
Operation	Output Specifications	Model Number	Timing Chart	Wiring Diagram	
Solid State Relay	SSR				
	SSR as NPN	xxxCV04SSR	Connector Status Connected Not Connected		
	SSR as PNP				
Analog	ANA	xxxCV04ANA			

TROUBLESHOOTING

<p>How does measuring piston travel correlate to verified connections?</p>	<p>By calibrating the movement of the piston, you can ensure a consistent connection. If the piston stops outside of the calibrated zone, you know that something in the setup has changed.</p>
<p>How do I know what calibration range to set?</p>	<p>It is application dependent and will require investigation by each specific user.</p>
<p>What impacts will the calibration range have on my test setup?</p>	<p>The larger range creates more consistent results, smaller ranges make the test more accurate but are more sensitive to variables such as pilot pressure, test piece, temperature, mounting, etc</p>
<p>Do I need to re-calibrate after changing seals?</p>	<p>For reliable performance, calibration should be performed after any substantial change to setup or process, including seal replacement.</p>
<p>Does the connector retain calibration points if it loses power?</p>	<p>Yes, the calibration points are stored on an internal memory.</p>

For any other questions, contact: fastsales@fastestinc.com

WARRANTY

FasTest Inc. warrants its products against defects in workmanship and materials for 12 months from the date of sale by FasTest Inc. or its authorized distributor. This warranty is void if the product is misused, tampered with or used in a manner that is contrary to FasTest Inc.'s written recommendations and/or instructions.

FasTest Inc. does not warrant the suitability of the product for any particular application. Determining product application suitability is solely the customer's responsibility. FasTest Inc. is not liable for consequential or other damages including, but not limited to, loss, damage, personal injury, or any other expense directly or indirectly arising from the use of or inability to use its products either separately or in combination with other products.

ALL OTHER WARRANTIES EXPRESS OR IMPLIED, WHETHER ORAL, WRITTEN OR IN ANY OTHER FORM, INCLUDING BUT NOT LIMITED TO WARRANTIES OF MERCHANTABILITY OR FITNESS FOR A PARTICULAR PURPOSE ARE EXPRESSLY EXCLUDED.

The sole and exclusive remedy under this warranty is limited to replacement of the product or an account credit in the amount of the original selling price, at the option of FasTest Inc. All allegedly defective products must be returned prepaid transportation to FasTest Inc., together with information describing the product's performance, unless disposition in the field is authorized in writing by FasTest Inc.

NOTES