

# OPERATING INSTRUCTIONS

7. Open the master vent valve and ensure that all pressure has been relieved from the manifold.
8. Disengage the connector bail; remove connector from cylinder valve and process in accordance with *(your company filling procedures)*.

## 540WOB “Walk o bout” Style Connector

### Recommended Operating Sequence

**Description:** G540041xWOB Pneumatic Activated Medical Oxygen Connector.

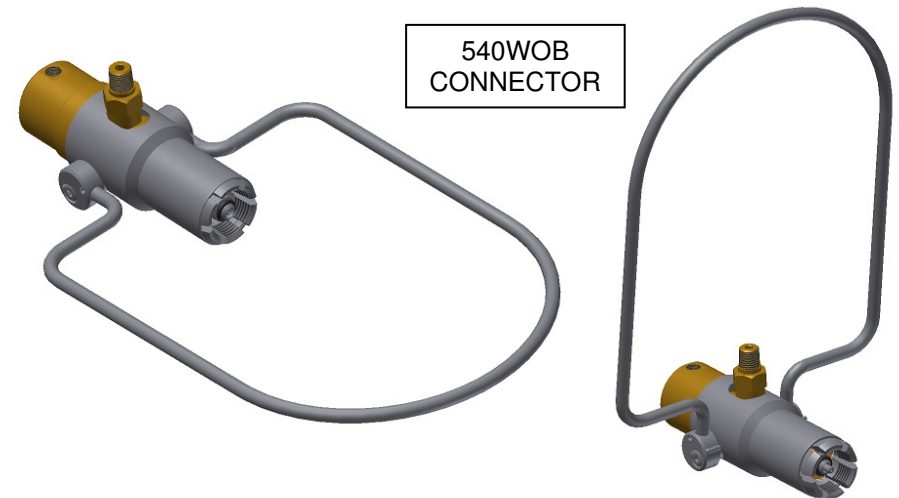
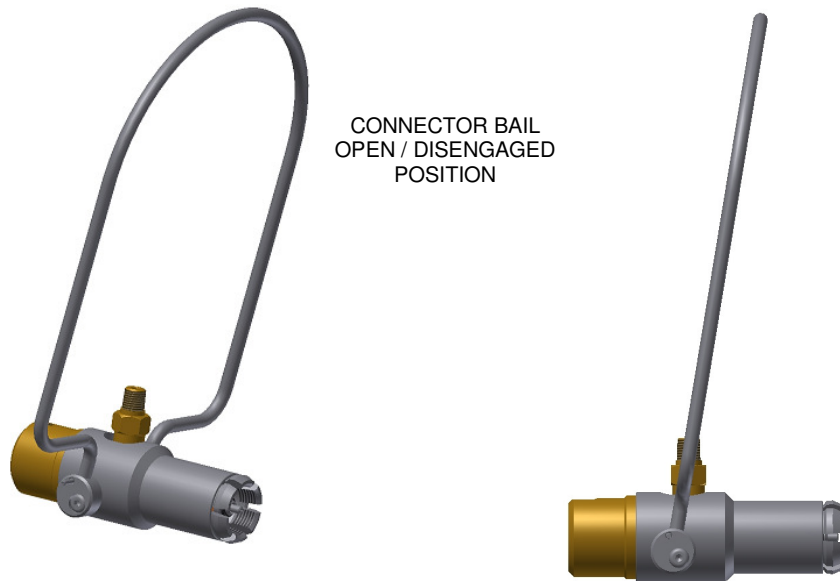

### FasTest, Inc. Product Warranty

FasTest, Inc. warrants its products against defects of workmanship and/or material for 12 months from the date of the sale by FasTest, Inc. This warranty is void if the product is misused, tampered with or used in a manner that is not in accordance with FasTest, Inc. recommendations and/or instructions. FasTest, Inc. is not liable for consequential or other damages including, but not limited to, loss, damage, personal injury, or any other expense directly or indirectly arising from the use of or inability to use its products either separately or in combination with other products. ALL OTHER WARRANTIES EXPRESSED OR IMPLIED, WHETHER ORAL OR WRITTEN, INCLUDING BUT NOT LIMITED TO WARRANTIES OF MERCHANTABILITY OR FITNESS FOR A PARTICULAR PURPOSE ARE EXPRESSLY EXCLUDED.

Remedy under this warranty is limited to replacement of the product or an account credit in the amount of the original selling price, at the option of FasTest, Inc. All allegedly defective products must be returned prepaid transportation to FasTest, Inc. along with information describing the products performance, unless disposition in the field is authorized in writing by FasTest, Inc.

Please thoroughly read the instructions prior to operating the 540WOB Connector. The 540WOB is designed to provide a safe, reliable leak-tight seal and connection when properly maintained and operated. If you do not understand instructions, or if components are missing, call *FasTest* before using connector.

- The connector is designed to mate with a specific application. Verify the application prior to the introduction of pressure or processing.
- Connectors are NOT designed for permanent connections and are for temporary connections only.

# OPERATING INSTRUCTIONS

## Operation:

(Follow your company cylinder filling operating procedures)

1. Align the *FasTest* connector with the cylinder valve and insert the connector onto the valve. Take care not to drop and or force the connector onto the cylinder valve as damage to the *FasTest* connector could occur.

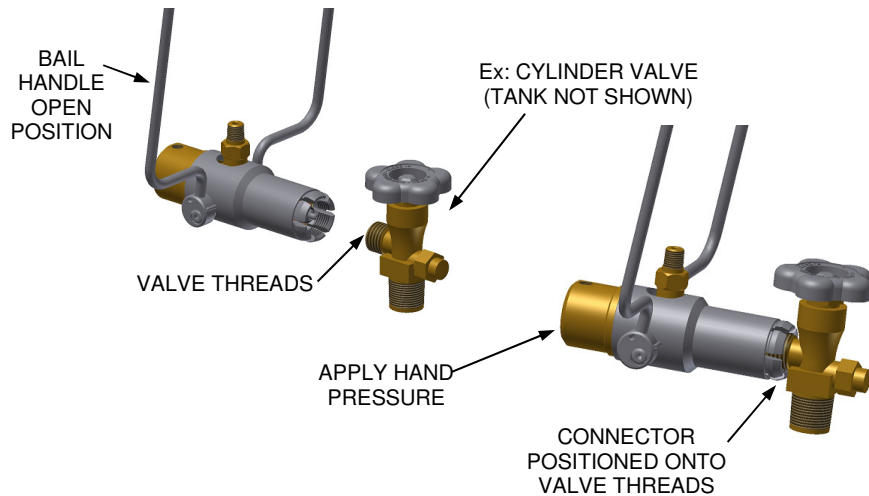

2. Once the *FasTest* connector is over the valve threads, engage the bail handle by rotating the handle down and over the valve. If the bail handle will not engage with relative ease, adjust the pressure to the back of the connector and try again. If the bail still does not engage easily, remove the connector from the cylinder valve and repeat the above steps. Over repeated and constant use, some minor equipment adjustments may be required.
3. Now that the *FasTest* connector has been successfully inserted onto the cylinder valve and bail handle has been fully rotated, make a quick visual and ensure that the connector is fully engaged with cylinder valve and has minimal threads showing. If connector is not fully engaged onto the valve threads, disengage the bail and apply adequate pressure to the carry handle to engage the cylinder valve further into the connector. Repeat bail engagement and visual check.

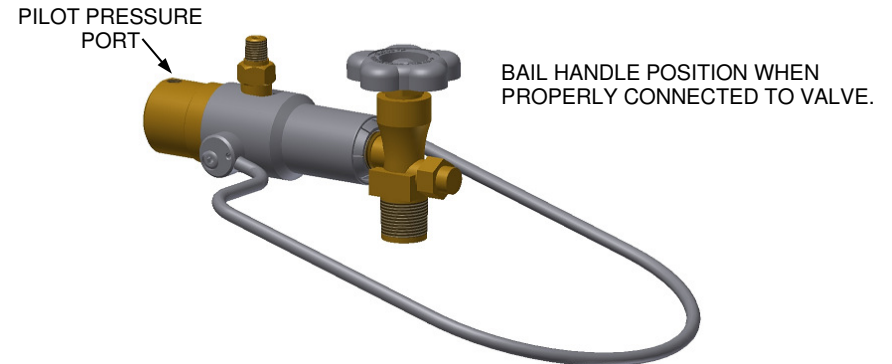

4. Once all cylinders are properly connected, open the toggle valve to supply pneumatic engagement (pilot pressure port) of the connector pin seal. Open the rack vent line and vent residual pressure. (Always follow your company filling procedures.)
5. Once vented and vacuumed and filled per (your company filling procedures) discontinue product flow and close the product supply valve to the manifold.
6. Close the toggle valve supplying pneumatic pressure to the (pilot pressure port) on the *FasTest* connector. This will retract the connector pin seal.

