

DESCRIPTION: FN FasMate Rebuild Instructions

Rebuild Kit Instructions for FN Style Connectors, body Size 1-4

Special Notes on Disassembly and Reassembly:

- **When connector has been disassembled, be sure to keep collets together as a set!**
- Torque requirements for shaft hex wrench sizes are as follows.
 - 3/32" Hex, torque to 30 in/lbs.
 - 7/64" Hex, torque to 46 in/lbs.

There are three different operator styles available for the FN FasMate connectors. Lever, Thumb Valve and Pneumatic.

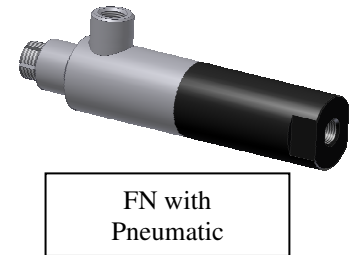
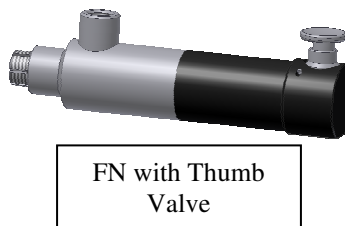
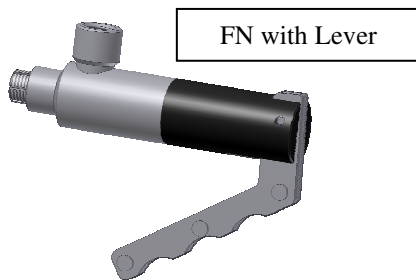

Disassembly:

1. Actuate connector by which ever way it is controlled. Lever, thumb valve or pneumatic pilot. Remove main seal and save.
2. Un-thread the back body from connector. (Lever style shown)
3. Using an adjustable wrench and hex wrench, remove the shaft from actuator. Some resistance will be felt because Loctite is used on shaft threads.

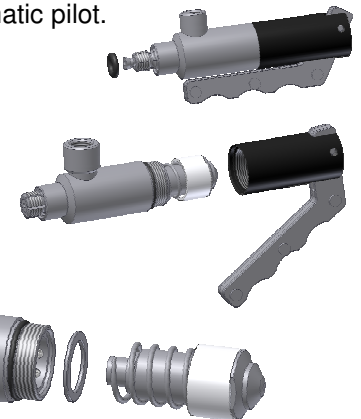
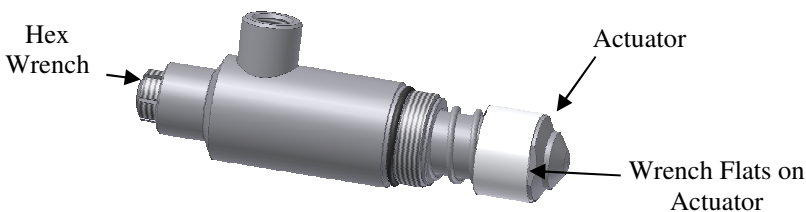

4. Remove the collet/piston/shaft assembly from the front body in the direction shown.

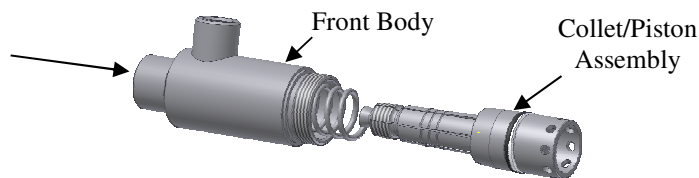

5. Remove and discard all seals, backup rings, spring's, and balls from assembly.
6. Pull shaft out of piston and collets.
7. Remove and discard o-ring and backup ring from inside piston. **All Body Sizes.**
8. Clean all parts prior to re-assembly.

Disassembly of FN's with Adapters:

1. Follow steps 1-3 from above.
2. Remove body adapter with adjustable wrench. Adapter is installed with a locking/sealing compound, might feel some resistance.

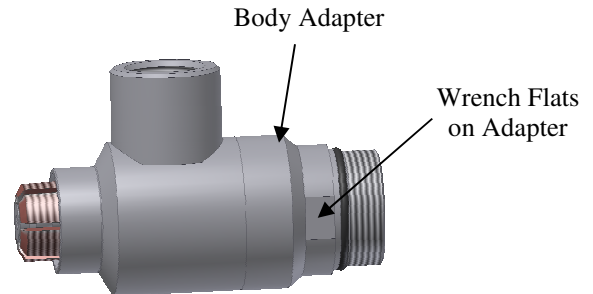

3. With the adapter removed the collet/piston/shaft assembly can be removed by pushing out of the front body as shown.

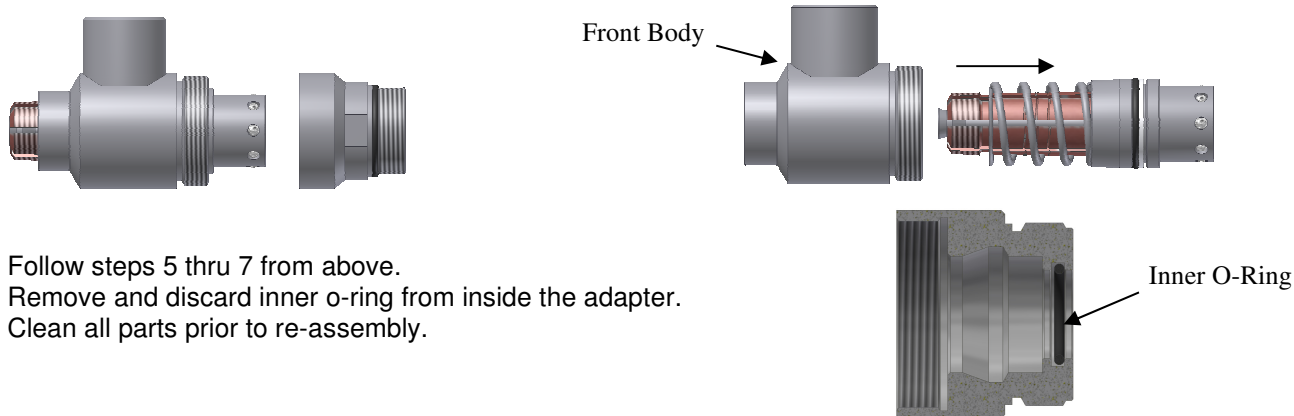

4. Follow steps 5 thru 7 from above.
5. Remove and discard inner o-ring from inside the adapter.
6. Clean all parts prior to re-assembly.

Reassembly:

Use all the new seals, springs, balls, and backup rings provided. Lightly lubricate seals with petroleum jelly.

1. Place o-ring and backup ring into groove on outside of the piston. All sizes.

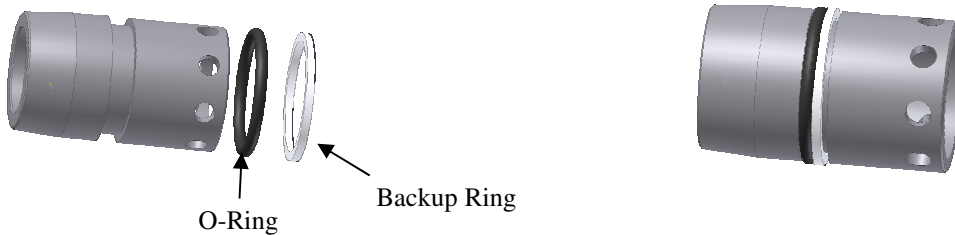

2. Apply Loctite Quicktape#249 to the threads on shaft. Apply 1-2 wraps pf tape. Liquid Loctite will not be sufficient as it could seep into unwanted areas of the connector. All sizes.



3. Align collets according to the timing line on the O.D. mid-section of the collet set. Insert the collets in accordance to the timing line into the piston as shown.
 - a. Install and use the shaft to center the collets. You may need to work the shaft in and out while inserting the collets to allow them to fall into place. All sizes.

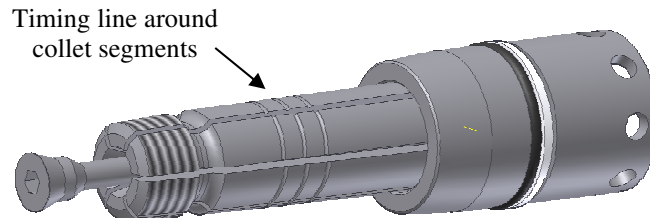

4. Install the small o-ring and backup ring over threaded end of shaft. Lubricate o-ring with petroleum jelly. The o-ring and backup ring should be fully inserted into the bore of the piston over shaft. **(Note: The front spring may be placed over the collets to help keep them in place.)**

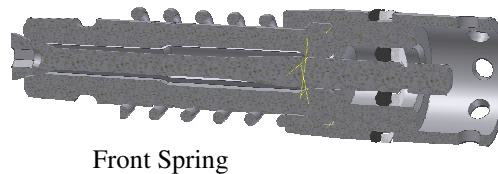
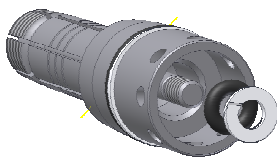

5. Place Delrin collar onto actuator, slide new spring onto actuator.
6. Stage washer between piston and the actuator spring.

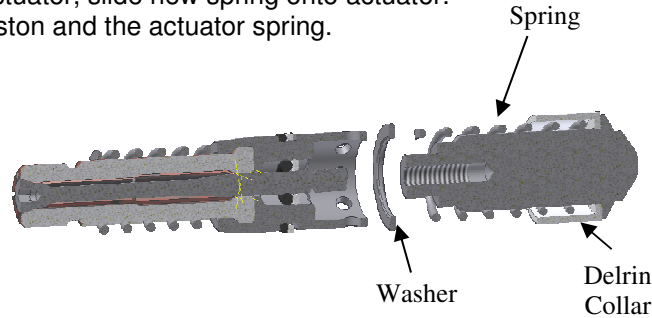

7. For connectors without body adapters (**size 2**), thread shaft into actuator prior to installing into front body. Use hex torque wrench to fully tighten.

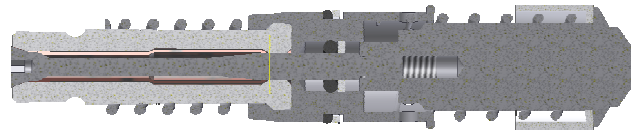

8. Place large o-ring into groove on front body (**size 2**). Insert the assembly from step 7 into the front body leaving ball holes exposed.

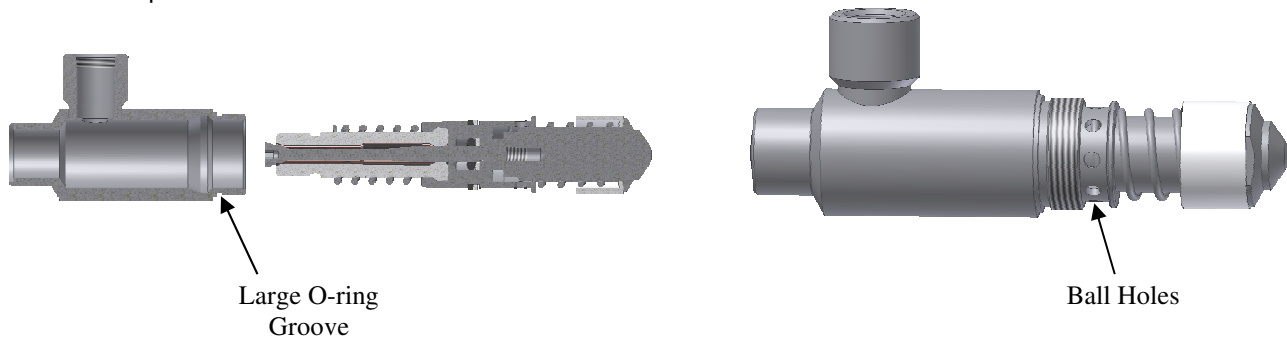

9. Coat ball holes with petroleum base jelly. Place balls into holes. Then push actuator forward so balls are slightly inside front body.
10. **For connectors with body adapters (sizes 1, 3 & 4), put the collet, piston, spring and shaft assembly together as done in steps 1-4.**
11. Install inner and outer o-ring's onto adapter.

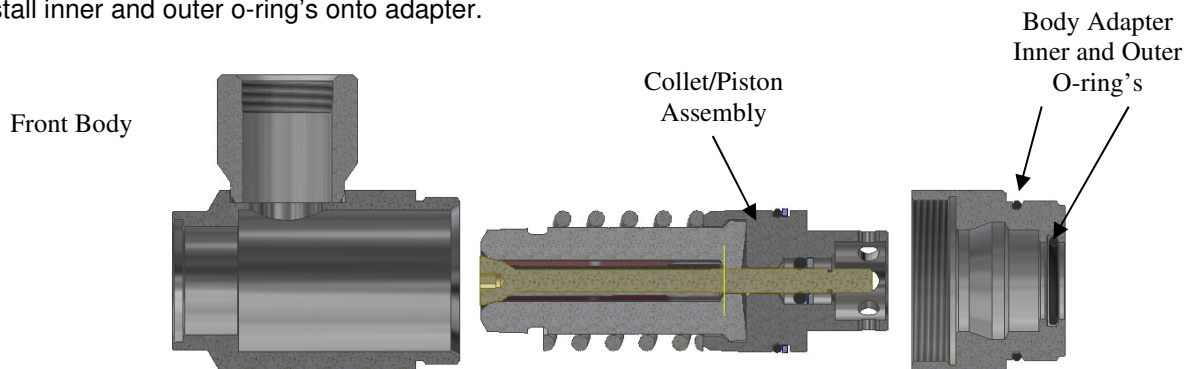

12. Slide the collet assembly into front body until spring hits shoulder inside front body.

13. Apply 2 to 3 drops of liquid Loctite #242 to front body threads.

14. Place adapter over piston and thread onto front body until tight to body.

15. Tighten adapter to 15 ft/lbs.

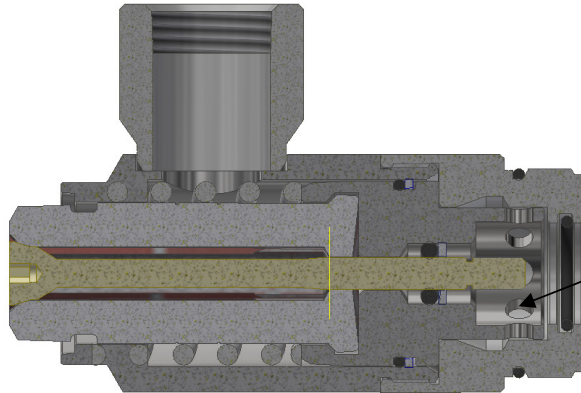
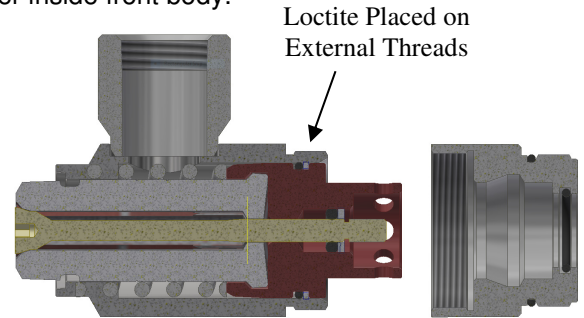

16. Coat the inside of the piston ball holes with petroleum jelly.

17. Place all balls into ball holes from inside the piston. The lube helps contain balls through the final steps of assembly.

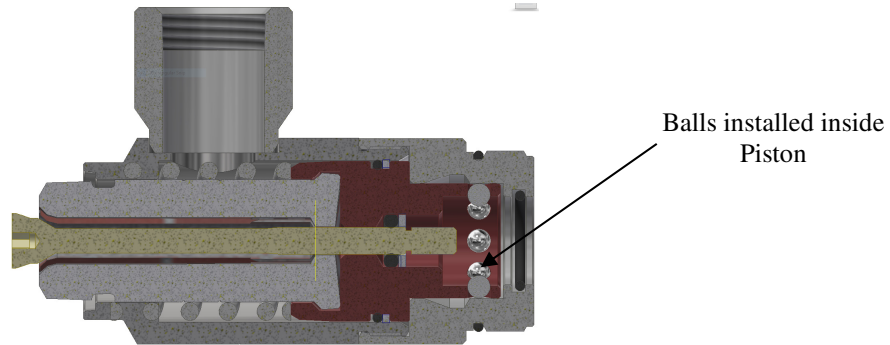

18. Place the delrin collar and new spring onto actuator. Using the correct hex wrench and adjustable wrench on actuator flats, tighten the shaft and actuator assembly together.

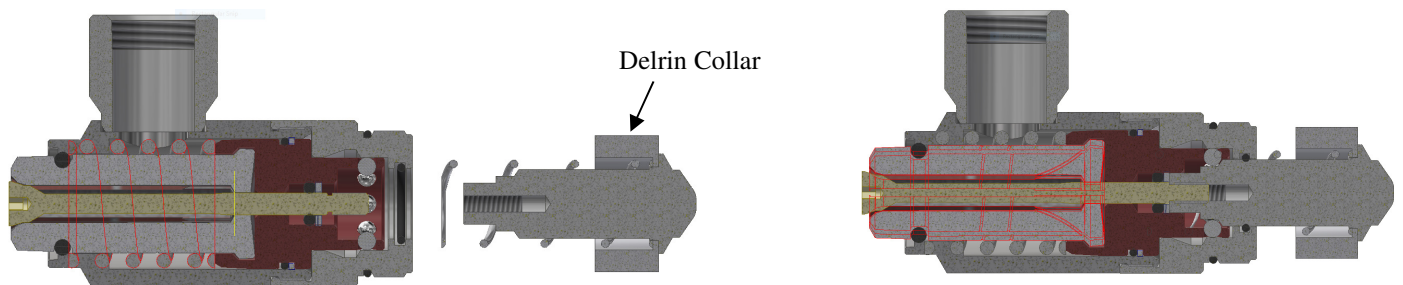

19. Now that connector sub-assembly is complete, thread which ever style control option you have back onto connector. (Lever, Valve or Pneumatic)

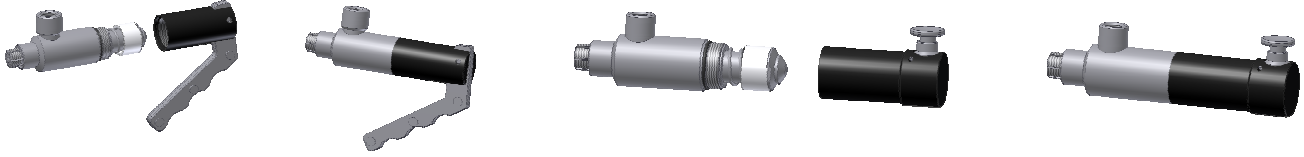

20. Actuate your connector to expose main seal groove in collets and install the main seal over the collets.

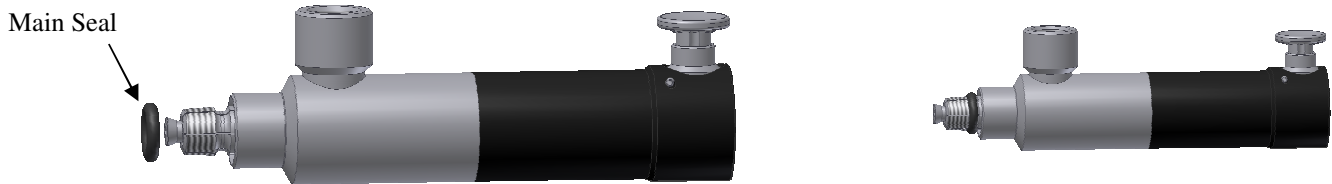

21. Actuate connector several times to ensure proper function and movement of the collets.

FasTest, Inc. Product Warranty

FasTest, Inc. warrants its products against defects of workmanship and/or material for 12 months from the date of the sale by FasTest, Inc. This warranty is void if the product is misused, tampered with, or used in a manner that is not in accordance with FasTest, Inc. recommendations and/or instructions. FasTest, Inc. is not liable for consequential or other damages including, but not limited to, loss, damage, personal injury, or any other expense directly or indirectly arising from the use of or inability to use its products either separately or in combination with other products. ALL OTHER WARRANTIES EXPRESSED OR IMPLIED, WHETHER ORAL OR WRITTEN, INCLUDING BUT NOT LIMITED TO WARRANTIES OR MERCHANTABILITY OR FITNESS FOR A PARTICULAR PURPOSE ARE EXPRESSLY EXCLUDED.

Remedy under this warranty is limited to replacement of the product or an account credit in the amount of the original selling price, at the option on FasTest, Inc. All allegedly defective products must be returned prepaid transportation to FasTest, Inc. along with information describing the products performance, unless disposition in the field is authorized in writing by FasTest, Inc.