

Connector Maintenance:

- A daily, weekly and periodic inspection of the connector by competent person is recommended. User must establish a regular interval for maintenance as determined by the user media and operational environment.
- Inspection should include visual checks of the sealing area, handle wear, missing or loose components, leak tightness, ease of operation, sufficient lubrication, wear, dirt accumulation and damage.
- Establish a regular interval for lubrication. The media and environment will be determining factors in establishing this interval to prevent dryness and/or corrosion.
- Difficulty of operation after continual use indicates a need for lubrication or other maintenance.
- Use only original **FasTest** spare parts that are designed for the application and are subject to strict quality control. See Warranty.

Safety Warnings – Guidelines:

- If instructions are not completely understood by operator or components are missing, contact **FasTest** before attempting use of the connector.
- Application Safety: All **FasTest** products have been designed with safety in mind, however, it is the responsibility of the products users to design each process in such a way to avoid mishaps that can cause physical hazard or property loss. Secondary restraints such as safety chains, shields, cages or fixtures are all good choices depending on the application. **FasTest** can recommend or assist you in clarifying potential hazards of your application.
- **FasTest 60/70** Connectors are not internally valved, and will not prevent loss of media when disconnected. Do not attempt to disconnect unless safe conditions are met.
- **FasTest 60/70** Connectors must only be used with test pieces of a specific size as indicated by the part number. Improper use could cause separation of the connector from the test piece resulting in physical harm or damage.

FasTest, Inc. Product Warranty

FasTest, Inc. warrants its products against defects of workmanship and/or material for 1 year from the date of the sale by FasTest, Inc. This warranty is void if the product is misused, tampered with or used in a manner that is not in accordance with FasTest, Inc. recommendations and/or instructions. FasTest, Inc. is not liable for consequential or other damages including, but not limited to, loss, damage, personal injury, or any other expense directly or indirectly arising from the use of or inability to use its products either separately or in combination with other products. ALL OTHER WARRANTIES EXPRESSED OR IMPLIED, WHETHER ORAL OR WRITTEN, INCLUDING BUT NOT LIMITED TO WARRANTIES OF MERCHANTABILITY OR FITNESS FOR A PARTICULAR PURPOSE ARE EXPRESSLY EXCLUDED.

Remedy under this warranty is limited to replacement of the product or an account credit in the amount of the original selling price, at the option of FasTest, Inc. All allegedly defective products must be returned prepaid transportation to FasTest, Inc. along with information describing the products performance, unless disposition in the field is authorized in writing by FasTest, Inc.

60/70 Series Connectors with ICON™

Description: *60/70 Series Connectors to Grip and Seal Male threads and Males Features with ICON™ CV04.*

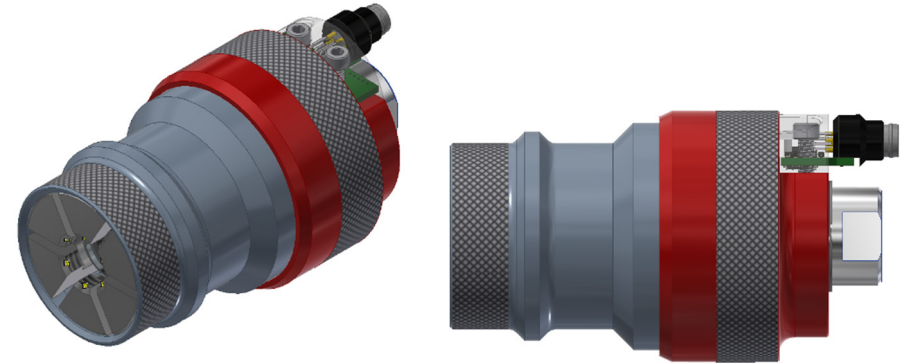

60/70 ICON™ Connectors provide a reliable leak-tight connection that grips and seals male threads and male features.

Please thoroughly read and understand these operating instructions prior to operating the connector. The use of pressurized media for sealing and testing requires a thorough understanding of the **FasTest 60/70** Operating Instructions.

- ICON™ Analog and SSR Calibration
- Installation
- Mechanical Operation
- Main Seal Replacement
- Connector Maintenance
- Safety Warnings – Guidelines

Analog and SSR Calibration Wiring Diagrams:

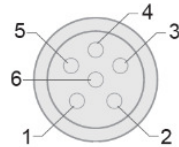
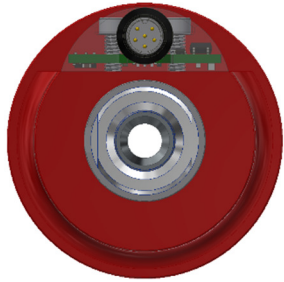

Pinout/Standard M8 Cables		
Pin Number	Wire Color	Description
1	BROWN	24 VDC
2	WHITE	CALIBRATION
3	BLUE	GROUND
4	BLACK	NC
5	GREY	SSR CONTROL A
6	PINK	SSR CONTROL B

CV04SSR PINOUT

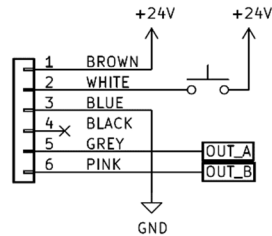

CV04SSR Wiring Diagram

Pinout/Standard M8 Cables		
Pin Number	Wire Color	Description
1	BROWN	24 VDC
2	WHITE	LED GREEN
3	BLUE	GROUND
4	BLACK	ANALOG OUTPUT
5	GREY	LED RED
6	PINK	LED RETURN

CV04ANA PINOUT

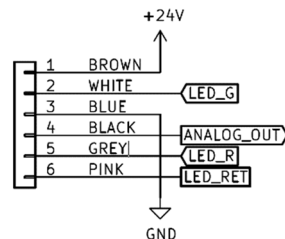

CV04ANA Wiring Diagram

SSR MODULE CALIBRATION, SLEEVE AND PISTON TRAVEL:

Sure Seal™ enabled connectors need to be calibrated to each application. **The 60/70 connector retains stored limit(s) even when power is removed.** Due to the fine sensor resolution and variations in seal height, limits may need to be set each time seals are replaced or the connector is re-built.

In order to calibrate the 60/70, the upper and lower limits will be calibrated by minimum and maximum piston positions **“with sleeve forward”**.

70 Series SSR Calibration:

DO NOT CONNECT MEDIA TO TERMINATION PORT ON CONNECTOR UNTIL CALIBRATION PROCESS IS DONE.

1. Single Point Calibration
 - a. Connect Sure Seal™ cable to the M8 Termination
 - b. Connect test piece and ensure connection is good
 - c. Enter calibration mode
 - d. Assert calibration signal until led begins flashing
 - e. Release calibration signal
 - f. Allow calibration mode to time out
 - g. Remove test piece from connector
2. Double Point Calibration
 - a. Connect Sure Seal™ cable to the M8 Termination
 - b. Enter calibration mode
 - c. Connect lower limit test piece
 - d. Assert calibration signal until LED begins flashing
 - e. Release calibration signal
 - f. Remove lower limit test piece
 - g. Insert upper limit test piece
 - h. Assert calibration signal until LED begins flashing
 - i. Release calibration signal
 - j. Remove upper limit test piece

60 Series SSR Calibration:

DO NOT CONNECT MEDIA SUPPLY TO TERMINATION PORT ON CONNECTOR UNTIL CALIBRATION PROCESS IS DONE.

1. Single Point Calibration
 - a. Single point calibration is not recommended for 60 series connectors
2. Double Point Calibration
 - a. Connect Sure Seal™ cable to M8 Termination
 - b. Connect test piece, then unscrew test piece until piston is not touching test piece
 - c. Screw in test piece just until a good seal is made
 - d. Enter calibration mode
 - e. Assert calibration signal until LED begins flashing
 - f. Release calibration signal
 - g. Remove test piece

ANALOG CALIBRATION, SLEEVE AND PISTON TRAVEL:

60 and 70 Series Analog:

1. Calibration is done in the installation by the intergrator, not on the connector.

Installation:

1. Connect supply line to the termination port.
2. Maximum termination pressure is marked on connector or literature.
3. Connect Sure Seal™ cable to the M8 Termination.

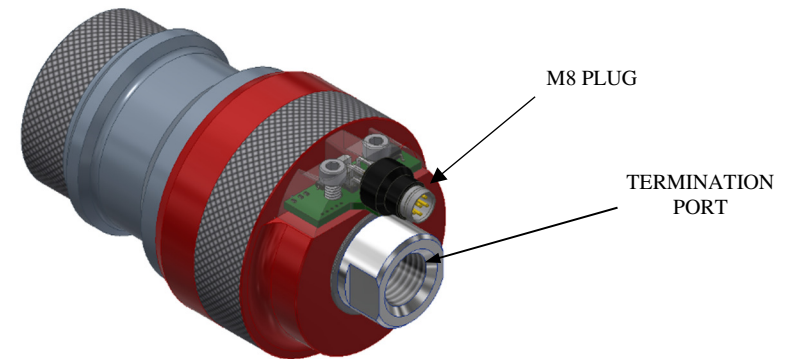

Mechanical Operation:

Connecting Action:

1. Slide the sleeve back or towards the red housing.
2. Collets and or Jaws will open up.

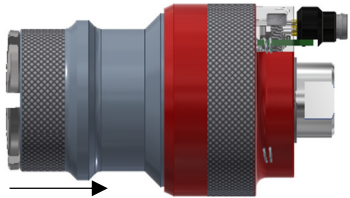

3. Push connector onto test piece. Collets/Jaws will connect/collapse onto fitting/tube type test piece.
4. Sleeve will spring forward and cover the collets/jaws.
5. Activate test pressure into termination port.
6. Maximum rated test pressure is marked on connector.
7. Run test.

Disconnecting Action:

1. Relieve test pressure.
2. Pull sleeve back and dis-connect from test piece.

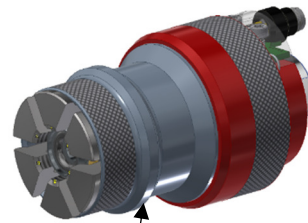

SLEEVE

MAIN SEAL REPLACEMENT:

1. In most cases the main seal can be extracted without dis-assembling the connector.
2. Slide sleeve back, jaws/collets will open.
3. Piston will come forward.
4. Using a pick like tool, extract main seal from piston. **(BE AS CAREFUL AS POSSIBLE NOT TO SCRATCH THE GROOVE SURFACES WHERE SEAL IS RETAINED!!)**

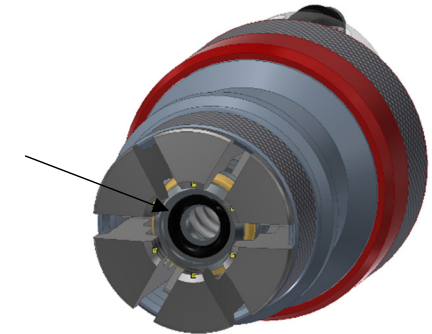

5. Remove and discard.
6. **Install new seal into groove on piston. DO NO LUBRICATE THE NEW MAIN SEAL!**