

GZNV / INTERNAL GAS BURNER TESTING

Internally valved manual sealing connection tool for Natural Gas or Propane Burner Testing.

CONNECTS TO:



SPECIFICATIONS

Pressure Rating	Operating Temperatures	Materials of Construction
Vacuum to 5 psi (0.345 bar)	0°F to +200°F (-17°C to +93°C)	Anodized Aluminum, Brass, Molded Nylon Handle
Termination Port		Seal Material*
1/4, 1/2 NPT		Gripper: Urethane Face Seal: Buna-N Internal: Buna-N

* Additional seal material types available, consult factory.

ACTUATION METHOD

Lever Handle: Two way actuation handle is simple and ergonomic for production applications.

Insert the connector into the gas valve and then actuate the handle. The gripper seal expands and pulls the face seal against the gas valve body, creating a seal between them and simultaneously opening the internal shutoff valve. This allows the flow of gas into the gas valve.

ICON™ TECHNOLOGY

Consult Factory

ACCESSORIES

Visit fastestinc.com

- 1 Lockable collar to keep sealing pressure consistent and internally valved to prevent gas flow once disconnected
- 2 Adjustable ring to accommodate the widest sealing range in the industry
- 3 Internal shut-off valve to stop the flow of gas when handle is in the disconnected position
- 4 Non-sparking aluminum and brass components

GZNV / INTERNAL GAS BURNER TESTING

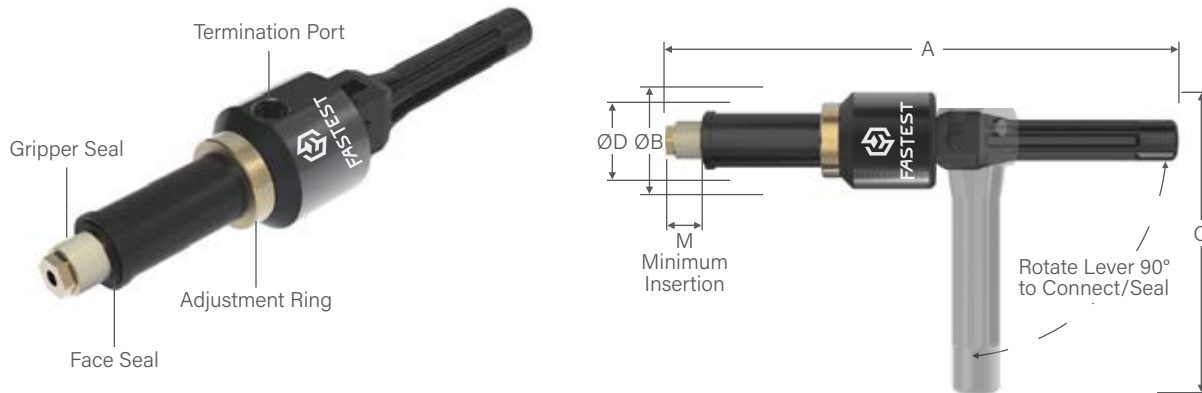

Ordering Information					Dimensions					
Connects To	Part Number	Replacement Seals Bulk Pack (5)	Rebuild Kit	Replacement Shaft	A	B	C	D	M	T

GZNV | With 2 in. (51 mm) Extended Shaft

3/8 NPT	GZNV0620410200	GZNVB062	GZNVR062	5ZNV27F380200	9.30 (236.2)	1.88 (47.8)	4.96 (119.1)	1.06 (26.9)	0.63 (16.0)	1/4 NPT
1/2 NPT	GZNV0820410200	GZNVB082	GZNVR082	5ZNV275BR0200						1/2 NPT
3/4 NPT	GZNV1220810200	GZNVB122	GZNVR122	5ZNV375BR0200	9.65 (245.1)	2.44 (61.9)	5.21 (132.3)	1.38 (35.1)		1/2 NPT

GZNV | Reduced Length Shaft

3/8 NPT	GZNV062041*	GZNVB062	GZNVR062	5ZNV27F38BR	7.30 (185.4)	1.88 (47.8)	4.96 (119.1)	1.06 (26.9)	0.63 (16.0)	1/4 NPT
1/2 NPT	GZNV082041*	GZNVB082	GZNVR082	5ZNV275BR						1/2 NPT
3/4 NPT	GZNV122081*	GZNVB122	GZNVR122	5ZNV275BR	7.65 (194.3)	2.44 (61.9)	5.21 (132.3)	1.38 (35.1)		1/2 NPT

Dimensions: inch (mm)

*Consult Factory for availability.

GasMate™ GZNV Family Flow Capacity

— Propane (3/4) - - - Propane (1/2) ⋯ Propane (3/8)
— Natural Gas (3/4) - - - Natural Gas (1/2) ⋯ Natural Gas (3/8)
— AIR (3/4) - - - AIR (1/2) ⋯ AIR (3/8)

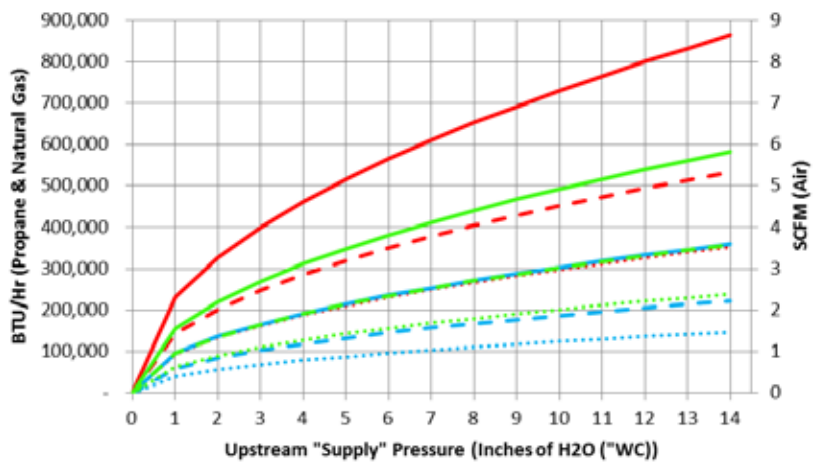

DON'T SEE A SOLUTION FOR YOUR APPLICATION? Submit a custom application form and drawing to fastsales@fastestinc.com or to your local distributor.