

CoreMax® / Valve & Seat Styles

CoreMax® Valve mates with the CoreMax® Seat to form the complete access valve.

MATES WITH COREMAX® SEAT FOR COMPLETE ACCESS VALVE:

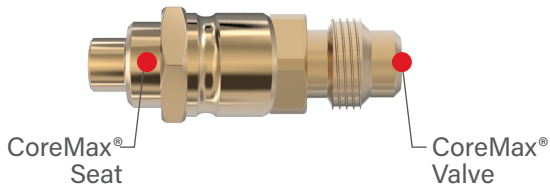

SPECIFICATIONS

Pressure Rating	Operating Temperatures	Materials of Construction
Vacuum to 700 psi (48.2 bar)	-40°F to +250°F (-40°C to +121°C)	Stainless Steel, Neoprene®

COREMAX® SEATS

For complete access valve.



- 1 Specifically designed for refrigeration applications maximizing flow and robust sealing technology.
The CoreMax® core utilizes one elastomeric seal to seal both the valve as well as the joint between the core and the seat. There is a metal to metal seal between the core and seat to ensure a complete seal.
- 2 The valve core pin position is manufactured to exact tolerances for consistent sealing and maximum valve opening for the highest flow available. The Valve conforms to ARI standard 720 for pin height
- 3

- Manufactured to exacting tolerances, the seat is designed to mate with the CoreMax® valve core and form the sealing capability
- Designed with gripping and sealing surfaces to work with the CoreMax® system tools Internally valved
- Many options are available to fit any user system

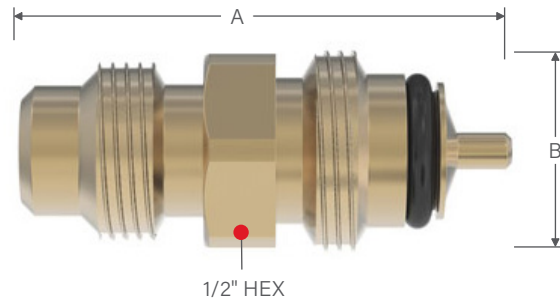

Ordering Information	Dimensions	
Part Number	A	B
CoreMax® Valve Mates with CoreMax® Seat for Complete Access Valve		
SCCA07H	1.00 (25.4)	1.00 (25.4)

Dimensions: inch (mm)

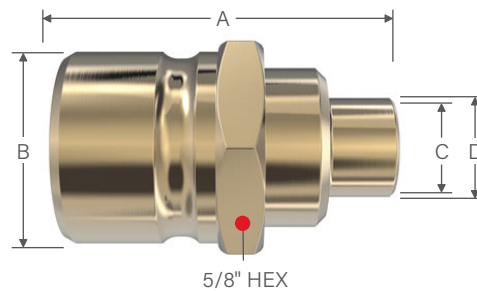

Ordering Information			Dimensions				
Style	Size	Part Number	A	B	C	D	Installed Length*
CoreMax® Seats Multiple Styles for User's Application							
Stub Tube	1/4	SCH0730A01	1.00 (25.4)	0.21 (5.3)	0.22 (5.6)	0.31 (7.9)	1.26 (32.0)
	3/8	SCH0730A03			0.32 (8.1)	0.43 (10.9)	
Saddle Mount	3/8 - 0.38 Hole	SCH0730B02	0.92 (23.4)	0.13 (3.3)	0.28 (.71)	0.37 (9.4)	
	1/4 - 0.22 Hole	SCH0730B03			0.07 (1.8)	0.17 (4.3)	
	1/4 - 0.25 Hole	SCH0730B04			0.13 (3.3)	0.18 (4.6)	0.25 (6.4)
Panel Mount	1/4	SCH0730C03	1.29 (32.8)	0.67 (17.0)	0.22 (5.6)	0.35 (8.9)	1.33 (33.8)
	3/8	SCH0730C04			0.35 (8.9)	0.44 (11.2)	
NPT	1/4	SCH0730E01	1.15 (29.2)	0.54 (13.7)	0.31 (7.9)	-----	

Dimensions: inch (mm)

* Installed length is CoreMax® Valve and CoreMax® Seat torqued together.