

REPLACEMENT INSTRUCTIONS



CMPT10, CMPT40, CMPT50 Main Seal Replacement Kit (S1015N70)

Description: Main Seal Replacement Kit for ZeroMax MBE, TRAVELER, AND SERVICE Tools.

Replacements steps:

1. As required, pull the shaft back to expose the main seals. With a small screwdriver or pick, remove the main seals from the tool and discard. Exercise caution so as to not scratch the o-ring grooves.
2. Lightly lubricate new seals with a petroleum-based jelly. Place the new seal inside the tool. Using a small screwdriver or blunt pick, push the seal into the respective groove. Repeat for second seal. Exercise caution so as to not harm the o-rings.

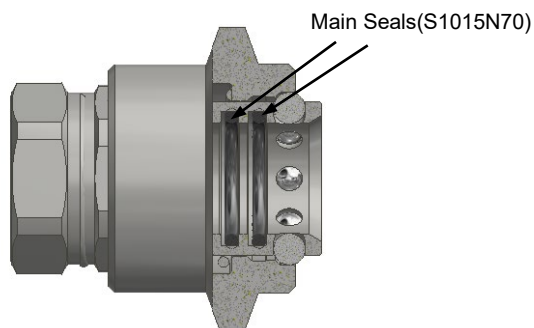
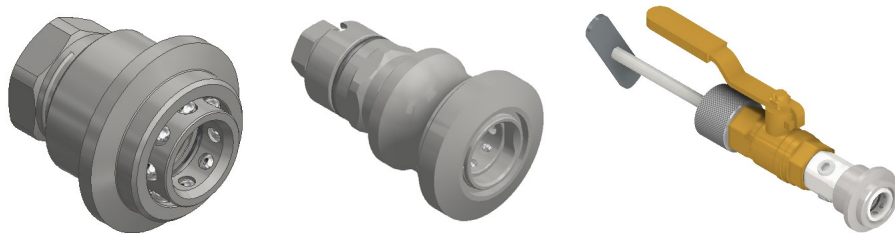

CMPT10 MBE Connector.
Section view to show seals.

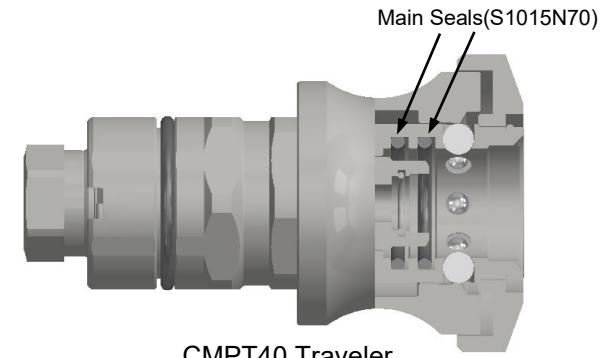

CMPT40 Traveler.
Section view to show seals.

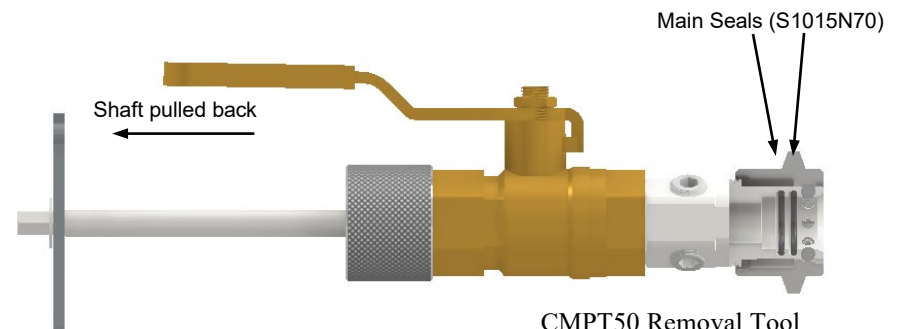

CMPT50 Removal Tool
Section view showing tool seals

FasTest, Inc. Product Warranty

FasTest, Inc. warrants its products against defects of workmanship and/or material for 12 months from the date of the sale by FasTest, Inc. This warranty is void if the product is misused, tampered with or used in a manner that is not in accordance with FasTest, Inc. recommendations and/or instructions. FasTest, Inc. is not liable for consequential or other damages including, but not limited to, loss, damage, personal injury, or any other expense directly or indirectly arising from the use of or inability to use its products either separately or in combination with other products. ALL OTHER WARRANTIES EXPRESSED OR IMPLIED, WHETHER ORAL OR WRITTEN, INCLUDING BUT NOT LIMITED TO WARRANTIES OR MERCHANTABILITY OR FITNESS FOR A PARTICULAR PURPOSE ARE EXPRESSLY EXCLUDED.

Remedy under this warranty is limited to replacement of the product or an account credit in the amount of the original selling price, at the option on FasTest, Inc. All allegedly defective products must be returned prepaid transportation to FasTest, Inc. along with information describing the products performance, unless disposition in the field is authorized in writing by FasTest, Inc.



Roseville, MN
Ph: 1-800-444-2373
Fax: 651-645-7390
www.fastestinc.com
WP195 07/27/2022